

Bluetooth Module MBH7BT08 Data Sheet

Rev. 0.05e
20 October 2002

FUJITSU MEDIA DEVICES LIMITED

All specifications are preliminary which may be changed without any prior notice

1. Introduction

This document applies to the Bluetooth Class 2 module MBH7BT08.

2. Features

MBH7BT08 is a Power Class 2 module conforming to Bluetooth Specification Version 1.1. MBH7BT08 transmits and receives in the 2.4 GHz ISM band. Although upper layer protocol stack and Profiles have to be embedded on the user's host system when user uses conventional HCI module, MBH7BT08 includes upper layer protocol stack and several Profiles. Therefore, MBH7BT08 makes it possible to reduce the resources of the user's host system required to process for Bluetooth.

MBH7BT08 has the following features:

- Bluetooth Specification Version 1.1 Compliant
- Built-in upper layer protocol stack (L2CAP, SDP, RFCOMM)
- Built-in profiles (GAP, SDAP, SPP)
- Transmit Power Class 2 (+4 dBm max.)
- Hardware interface: UART interface (up to 921.6 kbps)
- Software interface: Zerial interface (AT command-like)
- 3.3 ± 0.3 V Operation
- Bluetooth Qualification Program approved (planned)
- Microminiature: 19.5 x 13 x 2.2 mm
- Surface mount type

3. Block Diagram

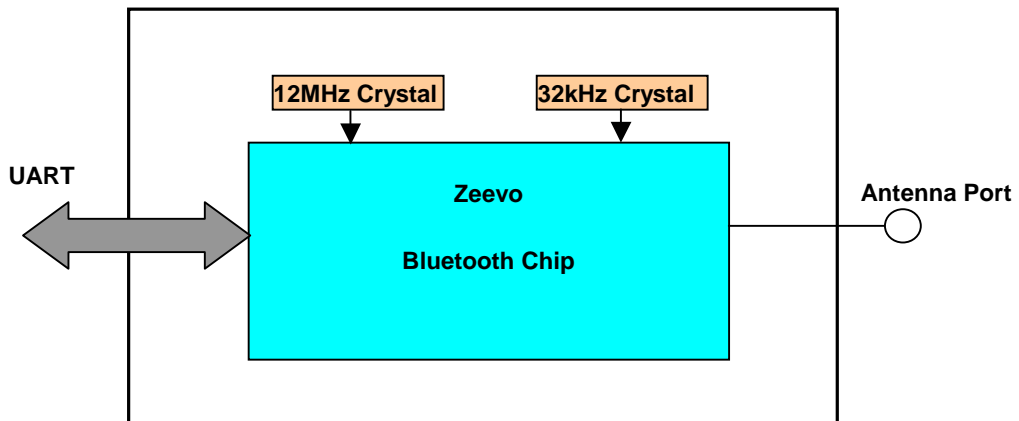

4. Electrical Characteristics

4-1. General Specification

Bluetooth™ Specification Version 1.1 Compliant

Carrier Frequency	2400MHz ~ 2483.5MHz
Modulation	0.5 BT Gaussian-filtered 2FSK at 1Msymbol/s Modulation index: 0.25 to 0.35
Symbol Rate	1Mbps
Channel	79ch
Channel Space	1MHz
Transmit Power	Power Class 2

4-2. Absolute Maximum Rating

Items	Symbol	Value	Unit
Supply Voltage	V _{cc}	+3.6	V
Input Voltage	V _{in}	-0.3 ~ V _{cc} +0.3	V
Storage Temperature	T _{stg}	-30 ~ +85	°C
RF input power	-	+15	dBm

4-3. Recommendable Operating Condition

Items	Symbol	Min	Typ	Max	Unit
Supply Voltage	V _{cc}	3.0	3.3	3.6	V
Operating Temperature	T _{opr}	0		+70	°C

4-4. I/O Terminal Characteristics

V_{cc}=3.3V, T_a=25°C

Items	Symbol	Min	Max	Unit	Test Conditions
Low-Level Input Voltage	V _{IL}	-	0.8	V	V _{cc} =V _{cc} Min
High-Level Input Voltage	V _{IH}	2.0	-	V	V _{cc} =V _{cc} Max
Low-Level Output Voltage	V _{OL}	-	0.4	V	V _{cc} =V _{cc} Min, I _{OL} =100μA
High-Level Output Voltage	V _{OH}	2.4	-	V	V _{cc} =V _{cc} Min, I _{OH} = -100μA
Low-Level Output Current	I _{OL}	-	2.2	mA	V _{OL} =0.4V
High-Level Output Current	I _{OH}	-	3.1	mA	V _{OH} =2.4V

4-5. Power Consumption

V_{cc}=3.3V, T_a=25°C

Mode	Min	Typ	Max	Unit
Power during Inquiry / Page scan	-	1.5	-	mA
Power during Inquiry / Page	-	20	-	mA
Power during connection (DH5 TX followed by DH1 RX)	-	55	-	mA
Power during connection (DM3 TX followed by DH1 RX)	-	50	-	mA

4-6. Transmitter Specification^{*1}

V_{cc}=3.3V, T_a=25°C

Items	Condition	Min	Typ	Max	Unit
RF transmit power	Maximum output	-2	1	4	dBm
RF power control range		-	30	-	dB
RF power range control resolution		-	3	-	dB
20dB bandwidth for modulated carrier		-	-	1	MHz
Initial Carrier Frequency Tolerance	DH1 mode	-75	-	+75	kHz
Carrier Frequency Drift	1 Slot	-25	-	+25	kHz
	3 Slot	-40	-	+40	kHz
	5 Slot	-40	-	+40	kHz
Modulation Characteristics	8 bit sequence 01010101	±115	-	-	kHz
	8 bit sequence 00001111 (Avg)	±140	-	±175	kHz
Adjacent Channel Power	M-N =2	-	-	-20	dBm
	M-N >=3	-	-	-40	dBm
Out of Band Spurious Emissions	30MHz --- 1GHz	-	-	-36	dBm
	1GHz --- 12.75GHz	-	-	-30	dBm
	1.8GHz --- 1.9GHz	-	-	-47	dBm
	5.15GHz --- 5.3GHz	-	-	-47	dBm

4-7. Receiver Specification^{*1}

V_{cc}=3.3V, T_a=25°C

Items	Condition	Min	Typ	Max	Unit
Sensitivity at 0.1% BER	DH1 mode	-	-75	-70	dBm
Sensitivity (single slot packets)	Input level = -70dBm	-	-	0.1	%
	DH1 mode	-	-	0.1	%
Sensitivity (multi-slot packets)	Input level = -70dBm	-	-	0.1	%
	DH5 mode	-	-	0.1	%
C/I performance		-	-	0.1	%
Blocking performance	30MHz ~ 12.75GHz	-	-	0.1	%
	Interferer signal	-	-	0.1	%
Intermodulation Performance	5 th order intermodulation	-	-	0.1	%
Maximum Input Level	Input level = -20dBm	-	-	0.1	%

*1) Measured according to the Bluetooth specification.

5. Pin Descriptions

Name	No.	I/O	Description	External connection
GPIO3	1	I/O	General Purpose Input / Output	NC
GND	2	---	Ground	Ground
ANT	3	I/O	Antenna RF port (50Ω)	Antenna (50Ω)
GND	4	---	Ground	Ground
TXD	5	O	UART data output	UART Rx/D
RXD	6	I	UART data input	UART Tx/D
PCM_SYNC	7	O	PCM Synchronous data strobe (This function is not available.)	NC
USB_D-	8	I/O	USB D- data input/output (This function is not available.)	NC
PCM_CLK	9	O	PCM Synchronous data clock (This function is not available.)	NC
RTS#	10	O	UART Ready To Send to DTE	UART CTS#
CTS#	11	I	UART Clear To Send from DTE	UART RTS#
USB_D+	12	I/O	USB D+ data input/output (This function is not available.)	NC
PCM_IN	13	I	PCM Synchronous data input (This function is not available.)	NC
PCM_OUT	14	O	PCM Synchronous data output (This function is not available.)	NC
RESET#	15	I	Reset input: active low for 5 ms (It is required for firmware update.)	Reset output or NC
GPIO0	16	I/O	General Purpose Input / Output	NC
GPIO2	17	I/O	General Purpose Input / Output	NC
GPIO1	18	O	CPU Activity (This terminal outputs high when the on-chip CPU is running and low when the device is in deep-sleep.)	Monitor input or NC
GPIO5	19	I/O	General Purpose Input / Output	NC
GPIO4	20	O	Baseband Activity (This terminal is high if there is any baseband activity.)	Monitor input or NC
GPIO6	21	I/O	General Purpose Input / Output	NC
GPIO7	22	I/O	General Purpose Input / Output	NC
GND	23	---	Ground	Ground
VCC	24	---	DC power (3.3V)	DC Power
GND	25	---	Ground	Ground
GND	26	---	Ground	Ground

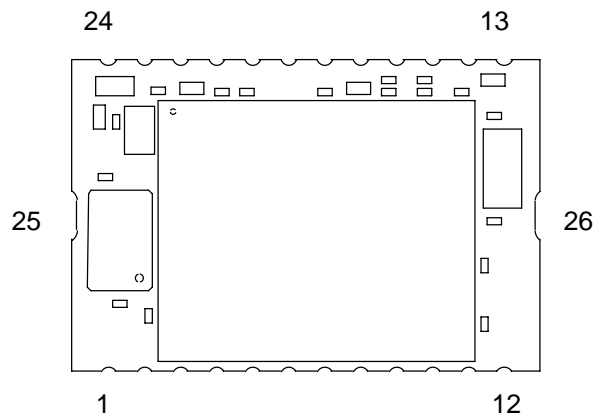

6. Interface Descriptions

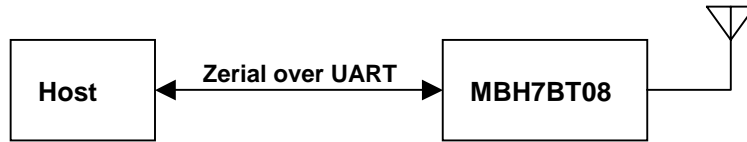

MBH7BT08 supports UART connection to its host. Also, MBH7BT08 supports the Zerial interface over UART. The Zerial interface is Zeevo's proprietary interface and supports AT-like modem commands.

6-1. Host Connection

MBH7BT08 Universal Asynchronous Receiver Transmitter (UART) interface provides a simple mechanism for communicating with the host. The UART is compatible with the 16450 industry standard.

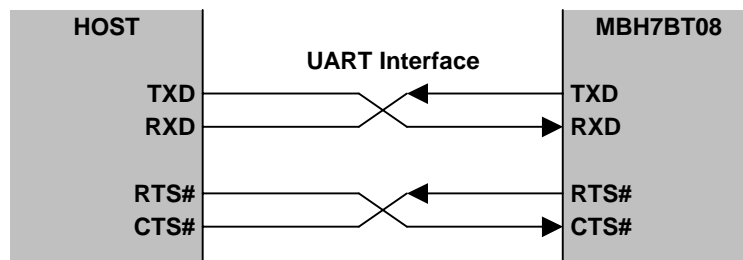

Figure 6-1: UART Interface

Four signals are used to implement the UART function, as illustrated above. When MBH7BT08 is connected to the host, UART_RX and UART_TX transfer data between both devices. The remaining two signals, UART_CTS and UART_RTS, can be used to implement hardware flow control. If CTS is de-asserted, MBH7BT08 stops transmitting data within one byte. When MBH7BT08 de-asserts RTS, by default it can accept up to 22 more bytes (i.e., the host is expected to stop transmitting within 22 bytes). All UART connections are implemented using CMOS technology and have signaling levels of 0V and Vcc (+3.3V nominal).

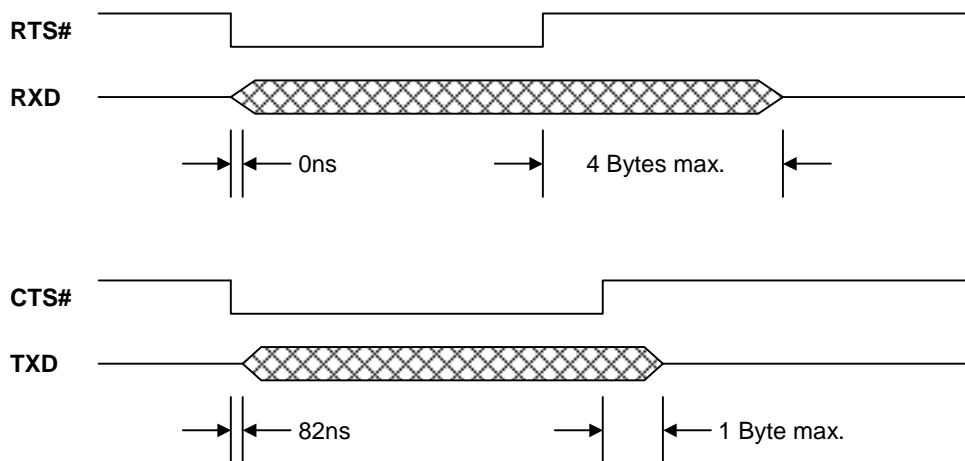

Figure 6-2: UART Timing Diagram

UART settings, such as baud rate and packet format, are following. The default baud rate can be configured using firmware setting software.

Table 6-1: UART settings

Parameter	Possible Values
Baud Rate	2.4k, 4.8k, 9.6k, 19.2k, 38.4k, 57.6k, 115.2k, 230.4k, 460.8k, 921.6k bps (The default baud rate is 115.2 kbps.)
Data bits	8 bits
Parity	None
Number of Stop bits	1 bit
Flow Control	Hardware flow control (RTS/CTS)

6-2. Software Interface

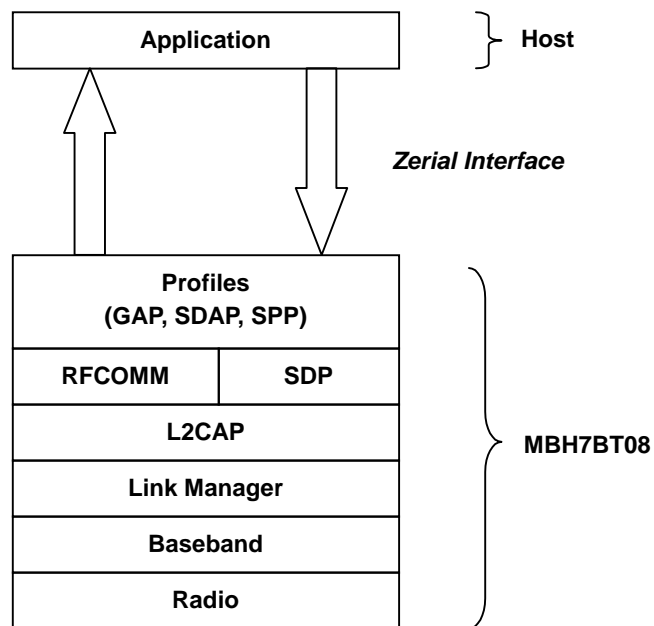

All components of the upper layer stack, lower layer stack and profiles (GAP, SDAP, SPP) are incorporated on MBH7BT08. The Zerial interface can be used for software interface between the host and MBH7BT08. The Zerial interface is Zeevo's proprietary interface. A user can use simple AT-like modem command set to run Bluetooth.

*GAP: Generic Access Profile

SDAP: Service Discovery Application Profile

SPP: Serial Port Profile

6-2-1. Zerial Interface

The software behavior of the Zerial interface is similar to a Hayes-compatible modem. The Zerial interface has two modes, a command mode and a bypass mode. In the command mode, the host can issue specially formatted text strings called commands. These command strings can be used for configuration or to manage a connection with a remote device. Note that the Zerial interface does not support the standard Hayes AT command set. Instead, it has commands that leverage off the vendor-specific command form.

Once a connection is established, the Zerial interface transitions to the bypass mode. In the bypass mode, All data sent from the host will be sent over the Bluetooth link to the remote device with the exception of the Escape sequence. Any data received from the remote device will be delivered to the host.

To move Zerial interface out of bypass mode and into the command mode, the Escape sequence is used. While in the bypass mode, the Zerial interface will search for this Escape sequence from the host. If this sequence is found, the Zerial interface will go back to command mode. This allows commands to be issued again from the host, but the connection to the remote device will remain. Any data received on the Bluetooth link will be discarded while in command mode.

While in the command mode, the Zerial interface will send responses back to the host for commands received. Responses from the Zerial interface will also be sent on system reset. These responses are not sent to the host during bypass mode. However, it is possible to configure a disconnect notification to be sent during bypass mode.

The remote device must at minimum be a device that supports the Serial Port Profile (SPP).

The Zerial interface can be used three different ways.

- (1) Initiate connections
- (2) Cable replacement
- (3) Standalone cable replacement

The first type of device will use the Zerial interface to initiate connections. Within this configuration, the Zerial interface can be used, through the command set, to discover other Bluetooth devices, initiate bonding with a remote device, and initiate a connection with a remote device. The Zerial interface currently only supports point-to-point SPP connections. Commands are issued through the host such as a PC or a second microprocessor.

The second type of device will use the Zerial interface to attach to a remote device acting as a cable replacement. The attached Zerial interface will accept connections initiated from a remote Bluetooth device and transfer data to/from the attached device over UART. It can also respond to a request from a remote device to bond. Since the Zerial interface setup occurs over UART, this configuration requires an additional controller.

The last configuration is similar to the second configuration with the difference being the Zerial interface operates entirely standalone. In this configuration, an external setup (through commands) is not normally available.

(1) Commands

All commands are formatted as follows.

AT+ZV Command [parameter] [parameter]

Where **Command** is replaced by the actual command name listed in Table 6-2. Any text following the command (and separated by spaces) is considered to be a parameter. All commands must terminate in a line-feed, carriage return, or both.

Tab characters, carriage returns, cannot separate parameters or line feeds. Parameters are shown in square brackets “[]”. The number of parameters and their values depend upon the command. Numeric parameters are given in hexadecimal, except where noted.

Table 6-2: Commands

Command Name	Response(s)	Summary
Bond [BD addr] [PIN]	BondPending [BD addr] BondOk [BD addr]	Change the UART baud rate
Bypass	-BypassMode- ConnectionDown	Set the CoD to use
ChangeBaud [rate]	Baudrate Changed	Disable bonding on the device
CoD [major] [minor]	CoDOk	Initiate a device discovery
DisableBond	BondDisabled	Enable bonding on the device
Discovery [CoD] [profile]	InqPending InqDone [num] Device [BD addr] [name] [service name]	Set the local name of the device
EnableBond [PIN] [BD addr] [timeout]	BondEnabled BondPending [BD addr] BondOk [BD addr] BondDisabled	Set the profile to use
LocalName [Name]	LocalNameOk	Reset the device
Profile [profile]	ProfileOk	Set the security level to use
Reset	ResetPending	Initiate a connection with the specified device
Security [level]	SecurityOk	Disconnect from the remote device
SPPConnect [BD addr]	ConnectionUp ConnectionDown	Request the interface version number
SPPDisconnect	ConnectionDown	Change the UART baud rate
Version	ZerialVer	Set the CoD to use

(2) Escape sequence

Once a connection has been established between host and remote device, the host can put the Zerial interface back into command mode. Once the Zerial interface is back in command mode, new commands (including termination of connection) can be issued. To move the Zerial interface out of bypass mode and into the command mode, the Escape sequence is used.

The Escape sequence is the string “^#^\$^%” followed by 2 seconds of no data. It must not be followed by a line-feed or carriage return. The Bluetooth connection to a remote device is not affected.

If the Escape sequence is received and no connection is active, the Zerial interface will immediately respond with

AT-ZV -CommandMode-

When the Escape Sequence is received while a connection is still active and there is no data for 2 seconds, the Zerial interface will respond (after those 2 seconds of no data) with the same string.

The Zerial interface will now be in command mode.

(3) Responses

All responses will be in the following format.

AT-ZV Response [parameter] [parameter]

Where **Response** is replaced by the actual response string listed in Table 6-3. Anything in square brackets, "[]", are parameters that depend upon the command. Numeric parameters will be returned in hexadecimal, except where noted.

Table 6-3: Responses

Response	Associated Command	Summary
###NO CARRIER	(none)	A remote disconnect has occurred while in the bypass mode.
-BypassMode-	(none)	The Zerial interface is currently in bypass mode.
-CommandMode-	^#^\$^% (Startup) (Remote disconnect)	The Zerial interface is currently in the command mode.
Baudrate Changed	ChangeBaud	The baud rate change request has been accepted.
BDAddress [BD addr]	(Startup)	The BD address of the local device.
BondDisabled	DisableBond EnableBond	Bonding with a new device has been disabled.
BondEnabled	EnableBond	Bonding has been successfully enabled.
BondFail	Bond EnableBond	A bonding attempt has been unsuccessful.
BondOk [BD addr]	Bond EnableBond	Bonding has been successfully completed.
BondPending [BD addr]	Bond EnableBond	Bonding is in progress.
CoDOk	CoD	The class of device has been successfully changed.
ConnectionDown	SPPConnect SPPDisconnect (Remote disconnect)	The connection with the remote device has terminated.
ConnectionUp	SPPConnect	The connection with a remote device has been successful.
Device [BD addr] [name] [service name]	Discovery	The results for one device during device inquiry, name request, and service search.
InqDone [num]	Discovery	A device inquiry has been completed, and [num] devices have been found.
InqPending	Discovery	A device inquiry has been initiated.
LocalNameOk	LocalName	The local device name has been successfully changed.
ProfileOk	Profile	The profile of the listening server has been successfully changed.
ResetPending	Reset	The reset command has been accepted and the reset is about to occur.
SecurityOk	Security	The security level has been successfully changed.
ZerialVer [ver]	Version	The version of the Zerial interface command set.

(4) Error

All error reporting will be in the following format.

AT-ZV Error

Where **Error** is replaced by the actual error string listed in Table 6-4.

Error reporting will provide information to the user to help describe the error that occurred.

Table 6-4: Error Reporting

Error string	Summary
ErrConnect	Command cannot be used while valid connection is up
ErrExecution	An error occurred in trying to execute the command
ErrFormat	Command issued that does not start with "AT+ZV"
ErrInvalidParam	One of the parameters is incorrect (could be invalid range or unrecognized symbolic name)
ErrNumParam	Too few parameters given
ErrUnknownCmd	Unrecognized command

(5) Responses after the reset

Upon either hardware reset or software reset (such as the Reset command), the Zerial interface will respond as follows after the reset is complete.

AT-ZV -CommandMode-

AT-ZV BDAAddress [BD addr]

Because the BD address of the local device is reported during this response, the response is different than a response to the Escape Sequence.

7. Mechanical Characteristics

7-1. Appearance and Dimensions

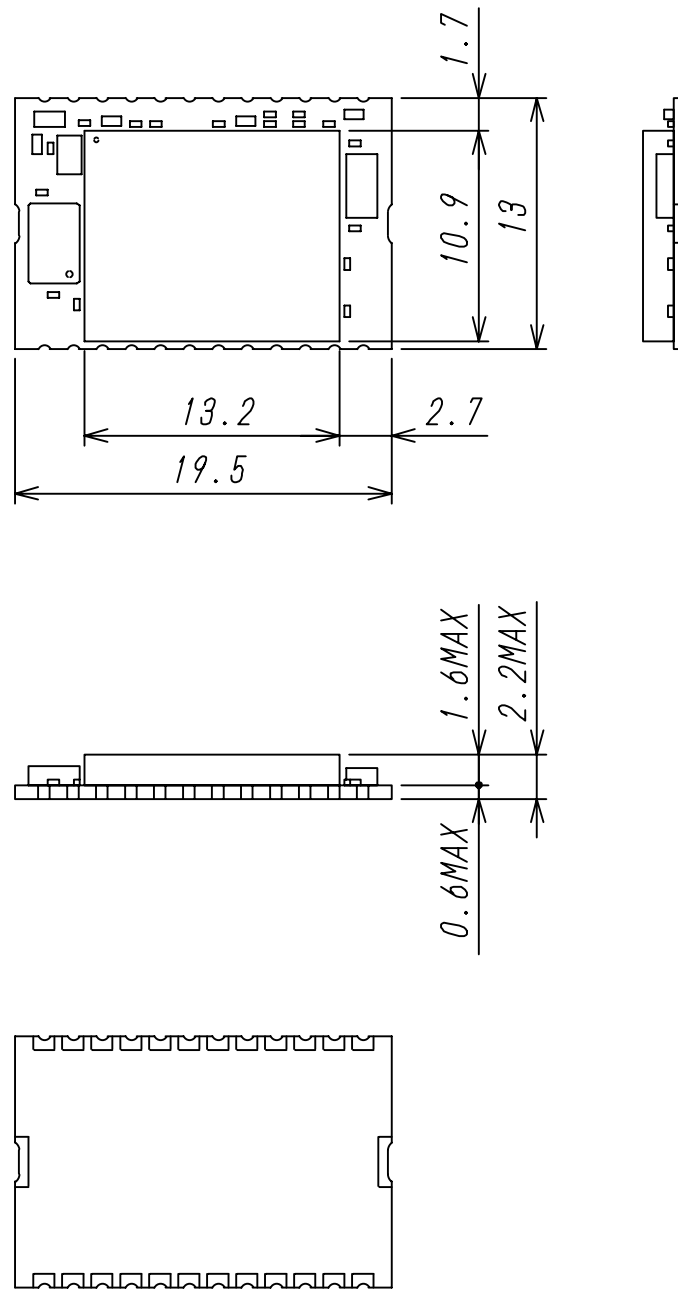

Unit: mm

7-2. Module Footprint (reference)

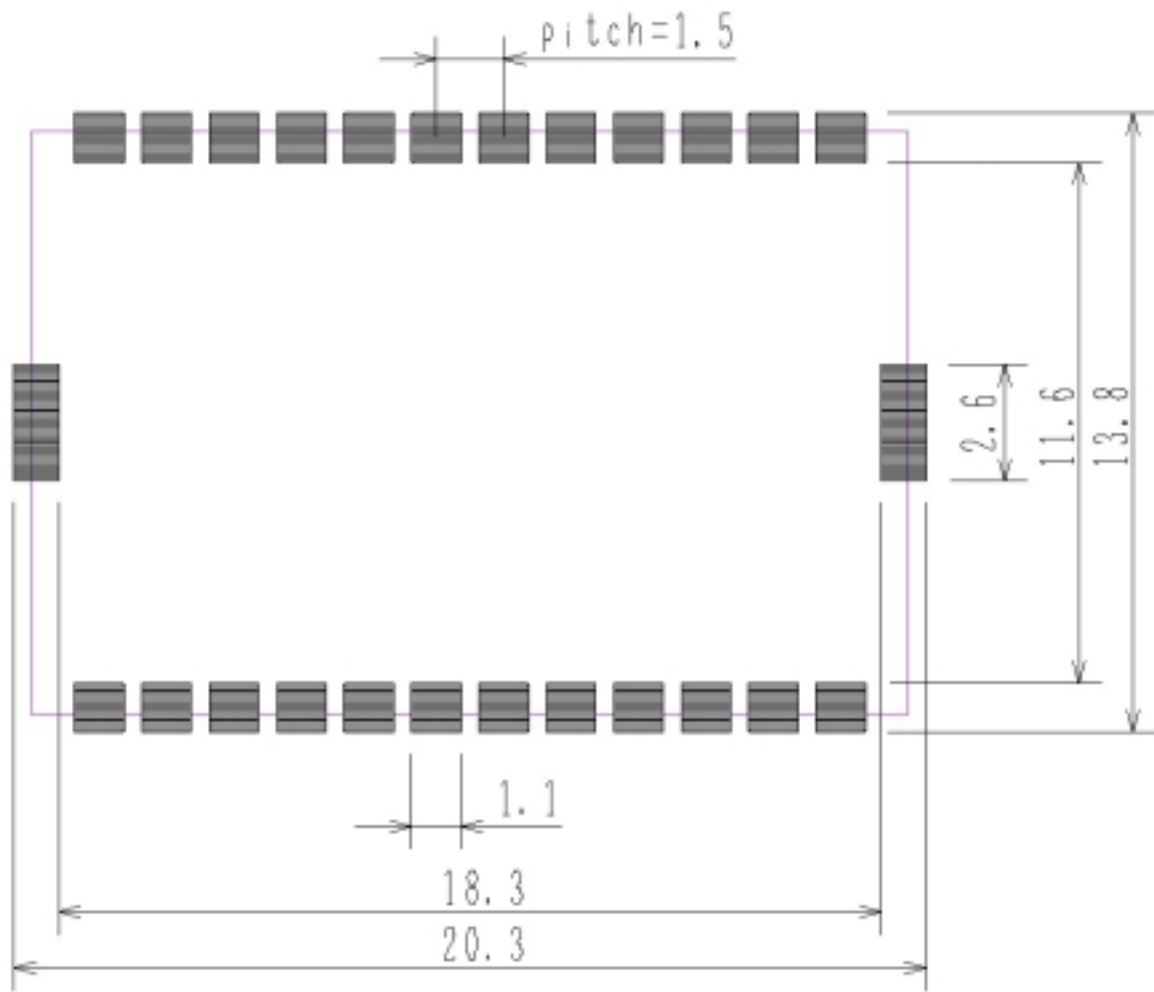

Unit: mm